

Keyhole

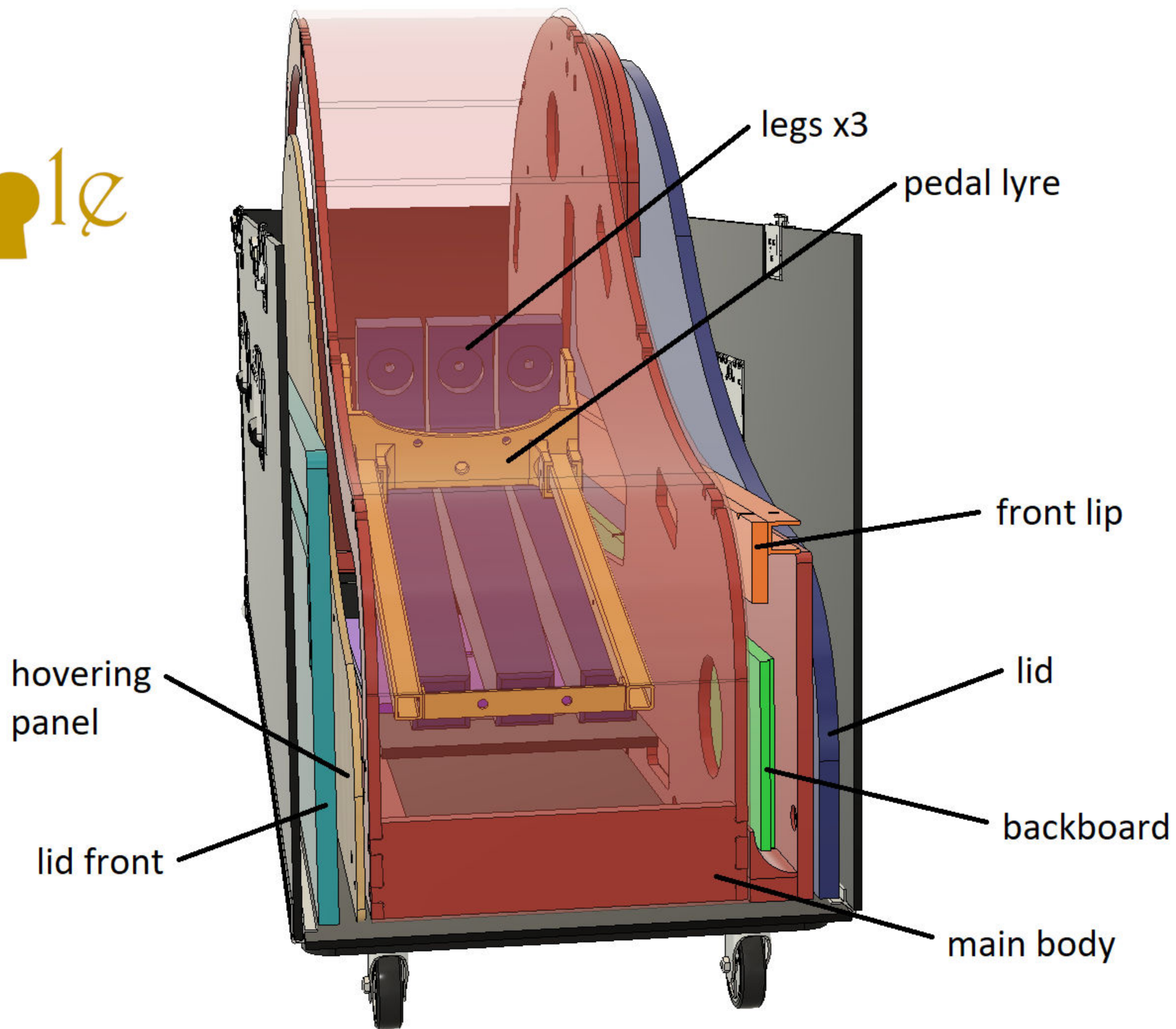

Keyhole

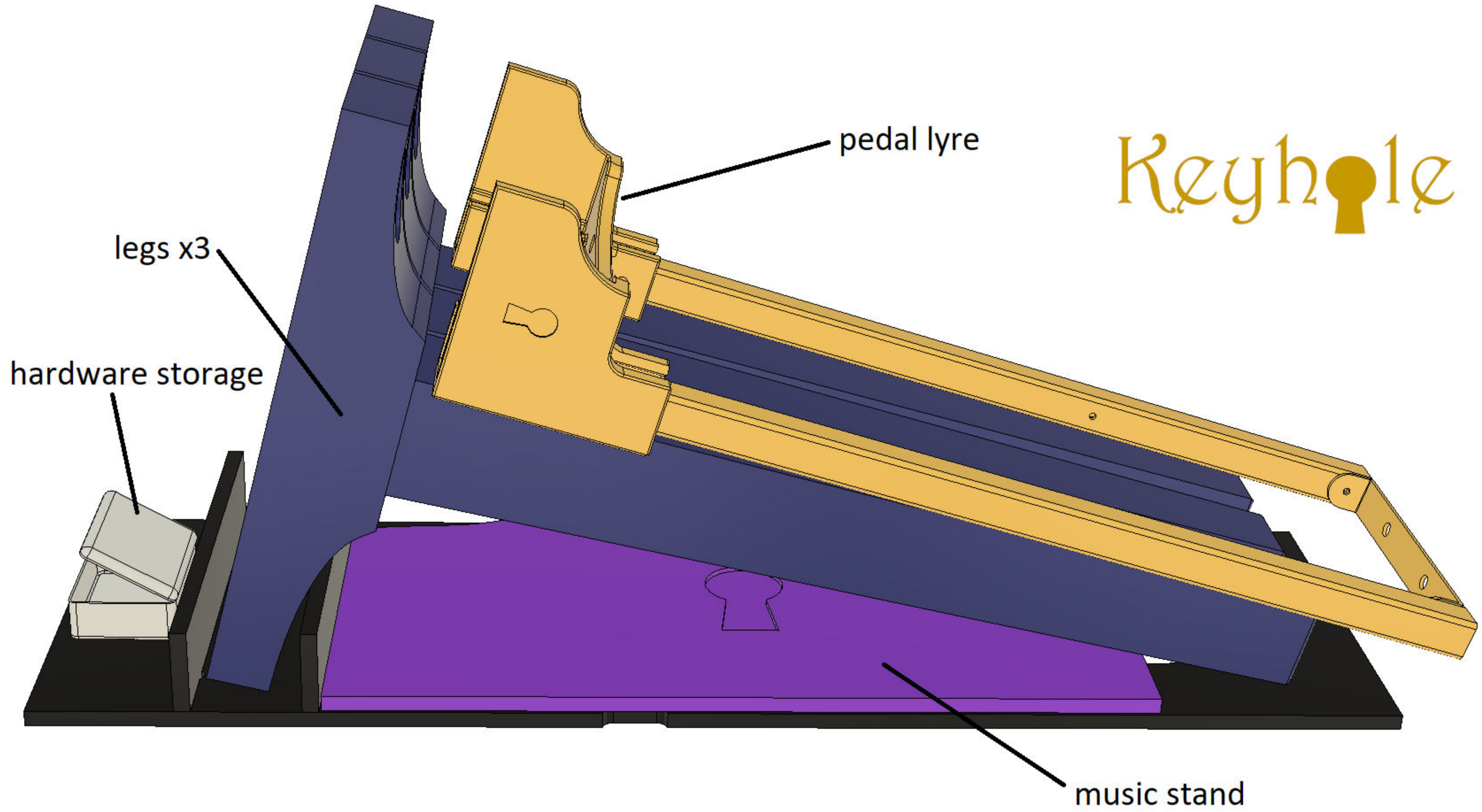

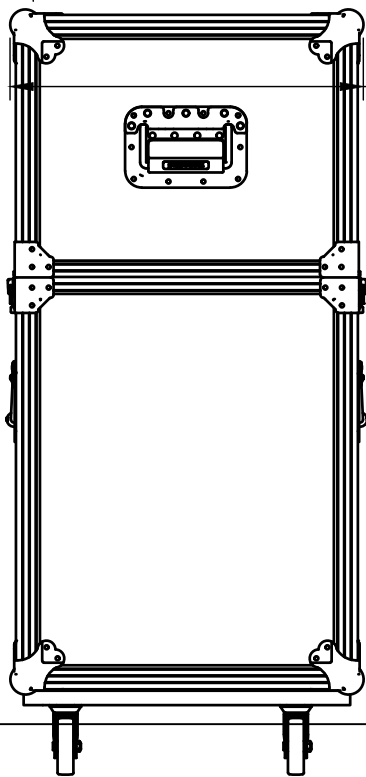
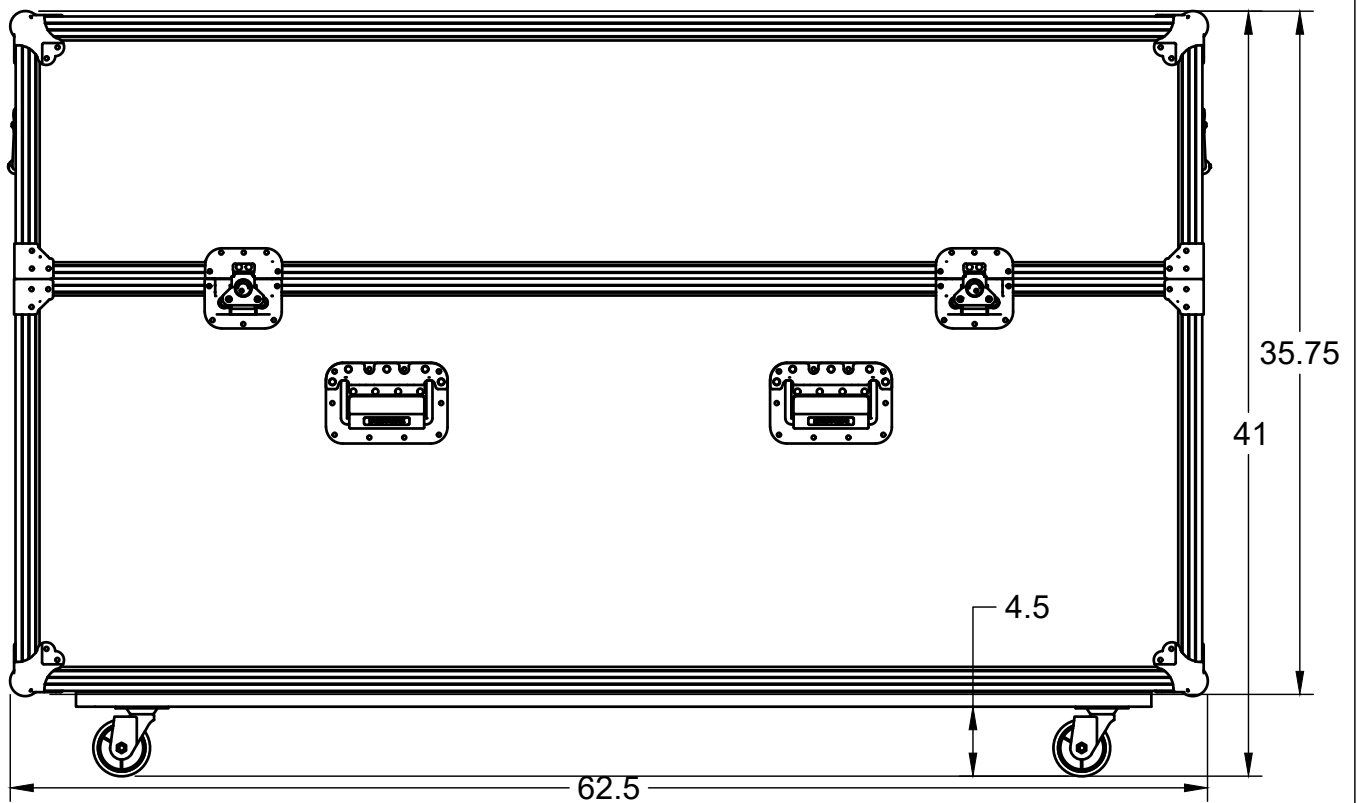

18.5

- ABS laminated 1/4-inch plywood panels
- Riveted aluminum extrusion along corners and tongue and groove extrusion along edges
- Large ball corners
- Reinforced handles
- Heavy duty latches
- 3-1/2-inch swivel casters attached to a 3/4-inch plywood base
- 1/2-inch foam interior lining

Generally secured to a pallet with casters removed and stored inside for shipping to customer

PROJECT

Keyhole Pianos

TITLE

RC 50 assembled

APPROVED

SIZE

CODE

DWG NO

REV

CHECKED

A

DRAWN

Michael Dhaseleer 6/2/2023

SCALE 1:16

WEIGHT

SHEET 1/1

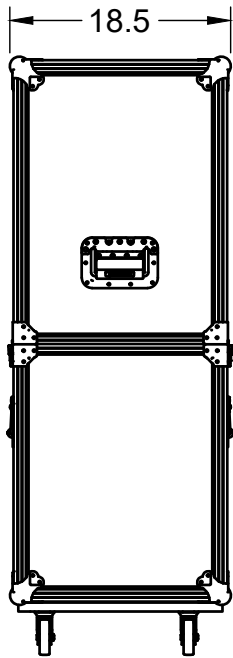
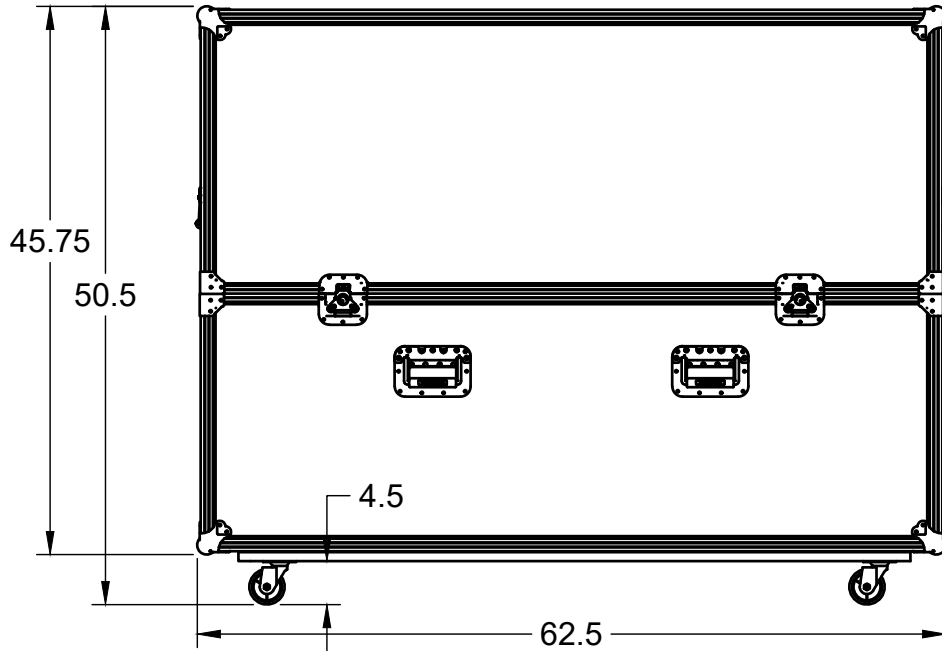

ABS laminated 1/4-inch plywood panels
 Riveted aluminum extrusion along corners
 and tongue and groove extrusion along
 edges
 Large ball corners
 Reinforced handles
 Heavy duty latches
 3-1/2-inch swivel casters attached to a
 3/4-inch plywood base
 1/2-inch foam interior lining

Generally secured to a pallet with casters
 removed and stored inside for shipping to
 customer

typical weight as shown is
 96 pounds

PROJECT

Keyhole Pianos

TITLE

RC 60 assembled

APPROVED

SIZE

CODE

DWG NO

REV

CHECKED

A

DRAWN

Michael Dhaseleer 6/2/2023

SCALE 1:16

WEIGHT

SHEET 1/1

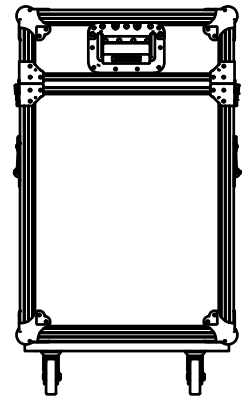
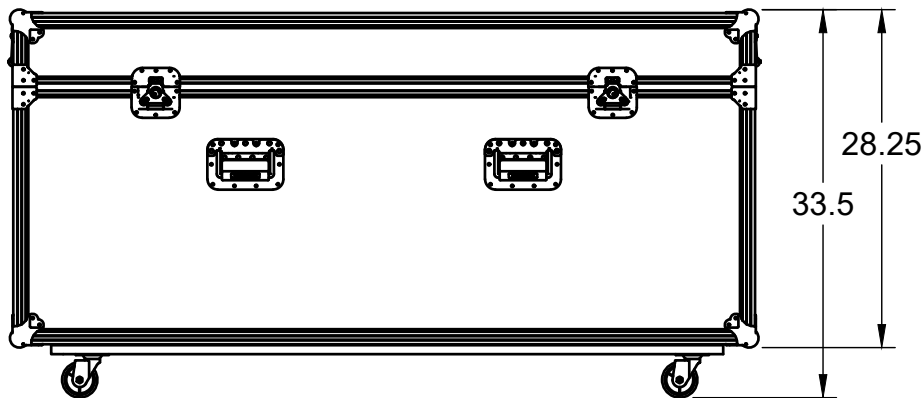
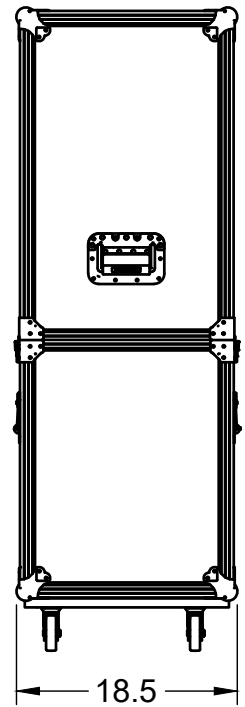
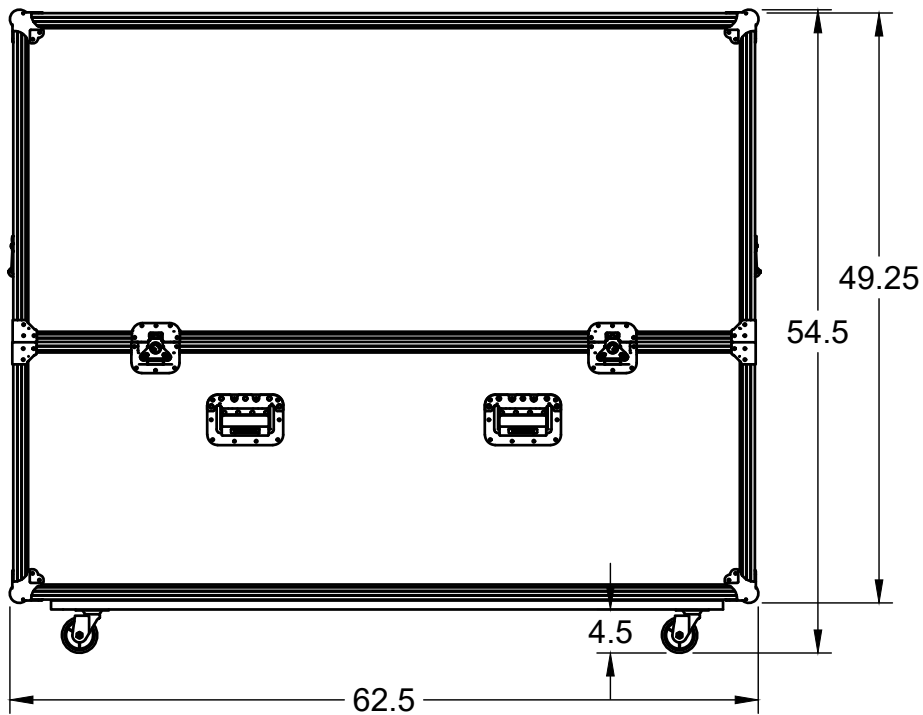

- ABS laminated 1/4-inch plywood panels
- Riveted aluminum extrusion along corners and tongue and groove extrusion along edges
- Large ball corners
- Reinforced handles
- Heavy duty latches
- 3-1/2-inch swivel casters attached to a 3/4-inch plywood base
- 1/2-inch foam interior lining

Generally secured to a pallet with casters removed and stored inside for shipping to customer

PROJECT	Keyhole Pianos		
TITLE	RC keybed and 72 assembled		

APPROVED	SIZE	CODE	DWG NO	REV
CHECKED	A			
DRAWN Michael Dhaseleer 6/2/2023	SCALE 1:16	WEIGHT	SHEET 1/1	